

Phase I : research and listing of local conditions for geothermal energy in France

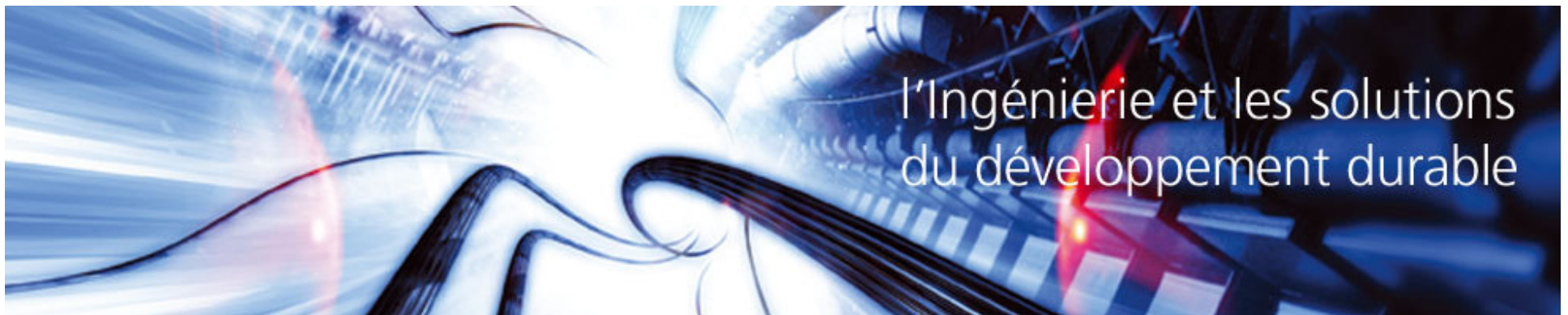

June 2008

Definition given by the International Standard Industrial Classification (ISIC)



- A - Agriculture, forestry and fishing
- B - Mining and quarrying
- C - Manufacturing
- D - Electricity, gas, steam and air conditioning supply
- E - Water supply; sewerage, waste management and remediation activities
- F - Construction
- G - Wholesale and retail trade; repair of motor vehicles and motorcycles
- H - Transportation and storage
- I - Accommodation and Food service activities
- J - Information and communication
- K - Financial and insurance activities
- L - Real estate activities
- M - Professional, scientific and technical activities
- N - Administrative and support service activities
- O - Public administration and defence; compulsory social security
- P - Education
- Q - Human health and social work activities
- R - Arts, entertainment and recreation
- S - Other service activities
- T - Activities of households as employers; undifferentiated goods- and services-producing activities of households for own use
- U - Activities of extraterritorial organizations and bodies

Energy consumption in France

Energy consumption in 2005 (Million tons of oil equivalent)
Total: 160 M TOE

After the French ministry of Industry

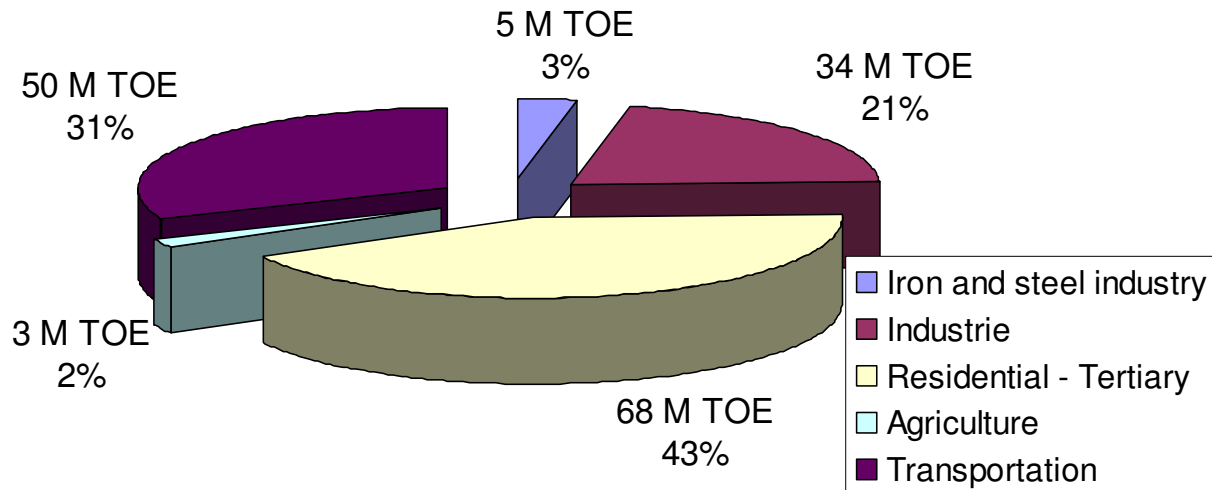

Repartition of the industry energy consumption in 2004

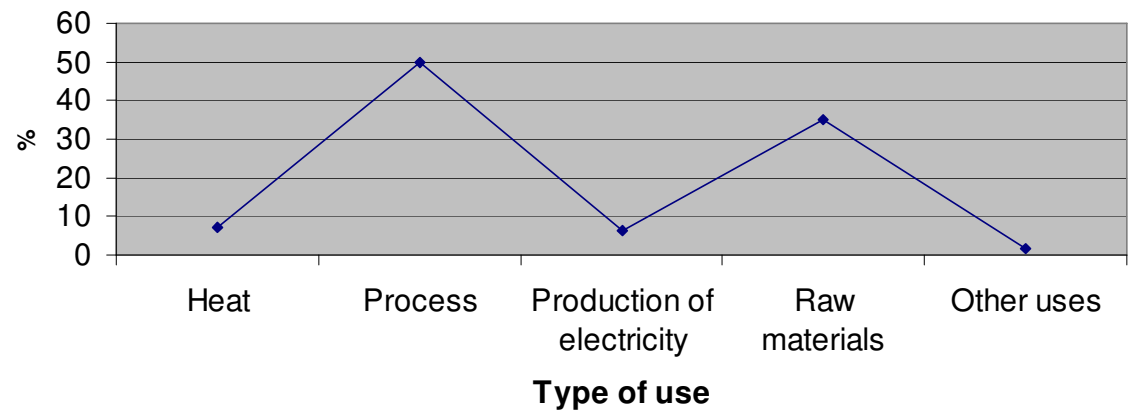

General conditions for geothermal applications

- Low enthalpy applications (30 to 90 °C)
 - oil field technology
 - authorization needed for drilling and for exploiting
- Very low enthalpy applications (Less than 30 °C)

Groundwater heat pumps

- spring water well drilling technology
- declaration if depth is less than 100 m and pumped volume below 200 000 m³ per year
- temperature regime : 12 – 7°C
- re-injection compulsory

Ground Heat Exchangers



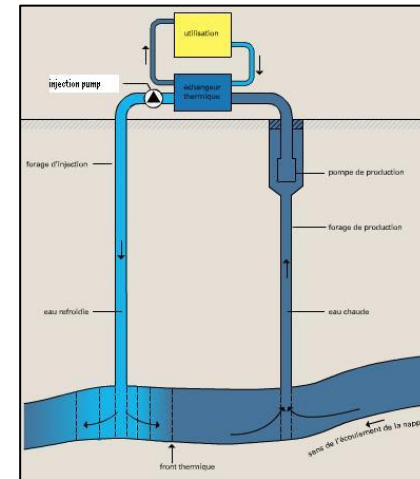

- declaration if depth is less than 100 m

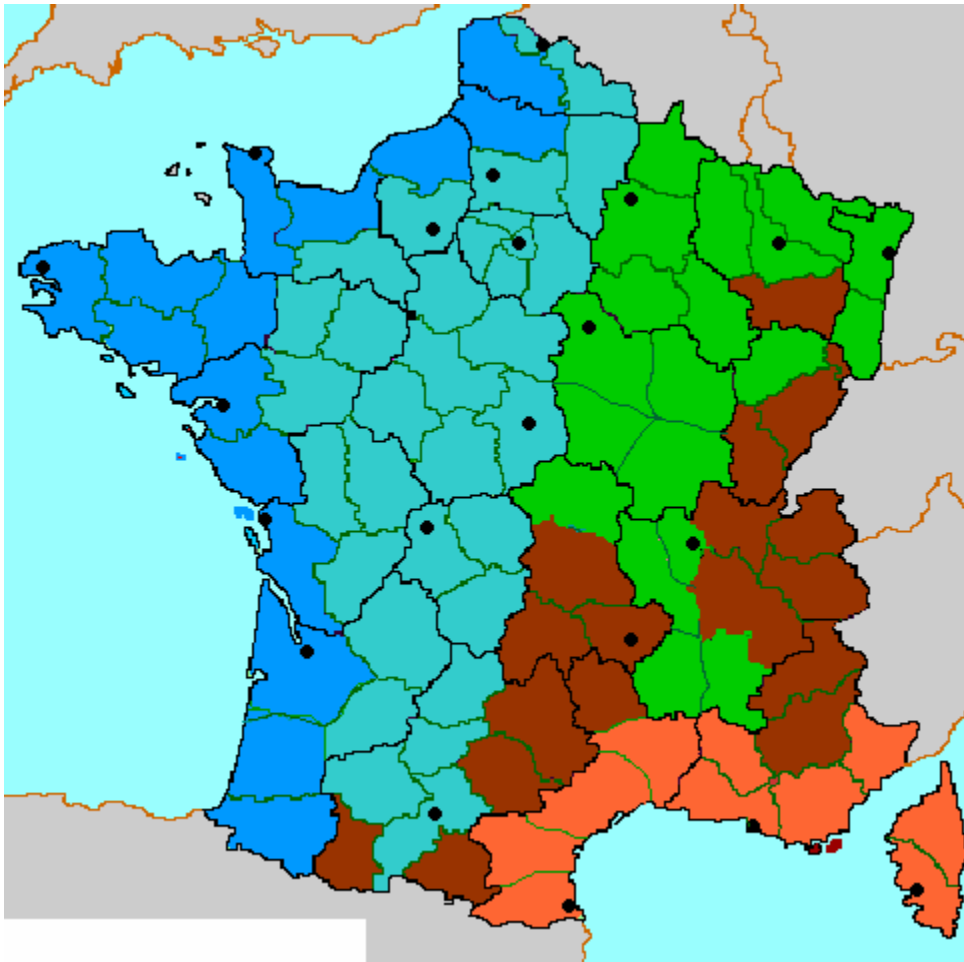

Separate double U-tube







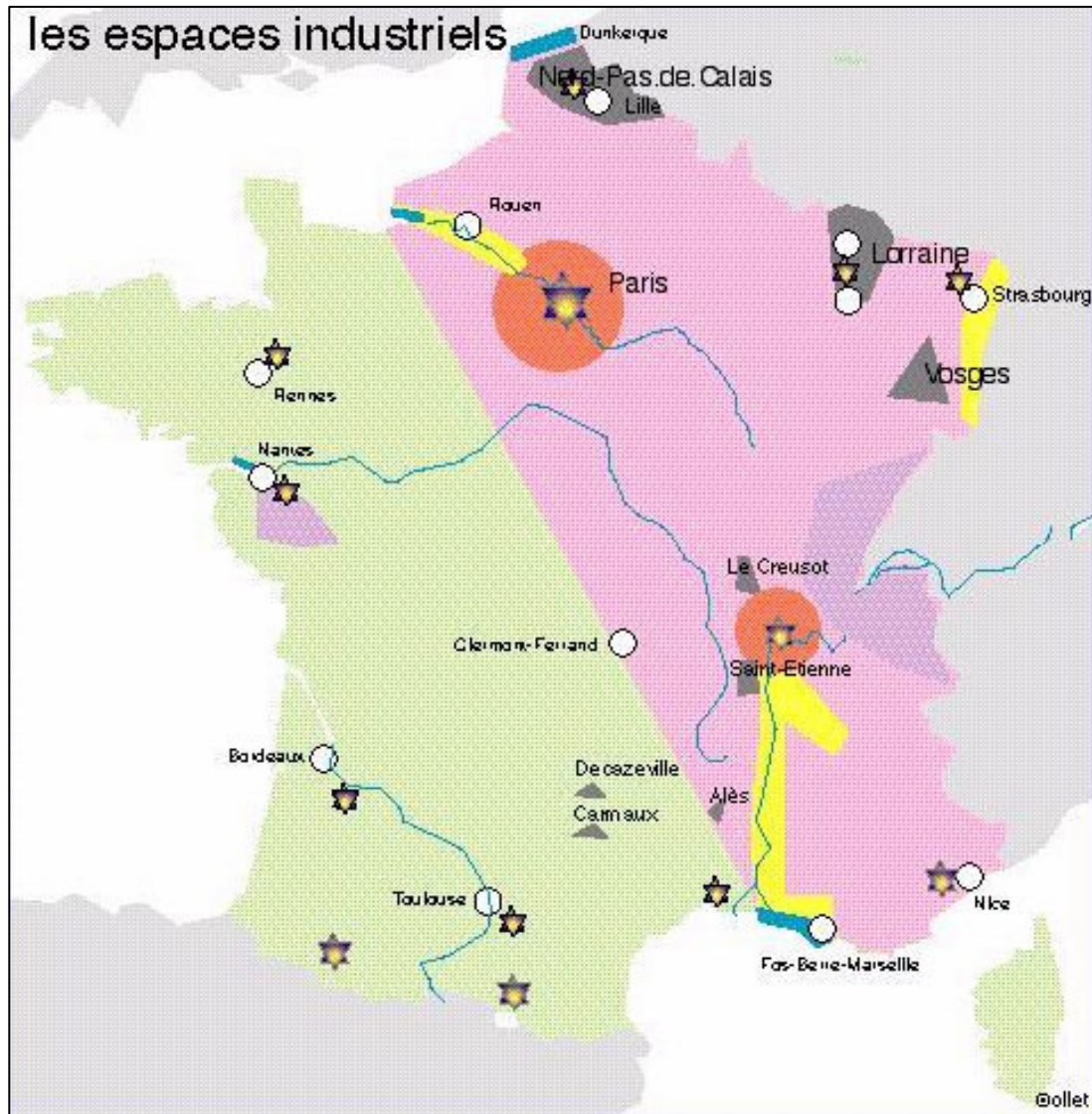

Climatic conditions



-  Oceanic: mild and wet winters (10 °C on average). Mild climate in summer
-  Shaded Oceanic: oceanic climate with continental influences
-  Continental: cold winter and hot summer
-  Mediterranean: very hot summer and mild winter
-  Mountain: cool summer and cold winter

Localization of the main industrial centers



-  70 % of industrial employment
-  Main industrial area
-  Industrial axis in movement
-  Old industrial areas
-  Extended industries in the countryside
-  Industrial agglomeration
-  Advanced technology industry
-  Remote industrial centers

Energy consumption per industrial sector - heating

Industry Energy Consumption for heating (2004)

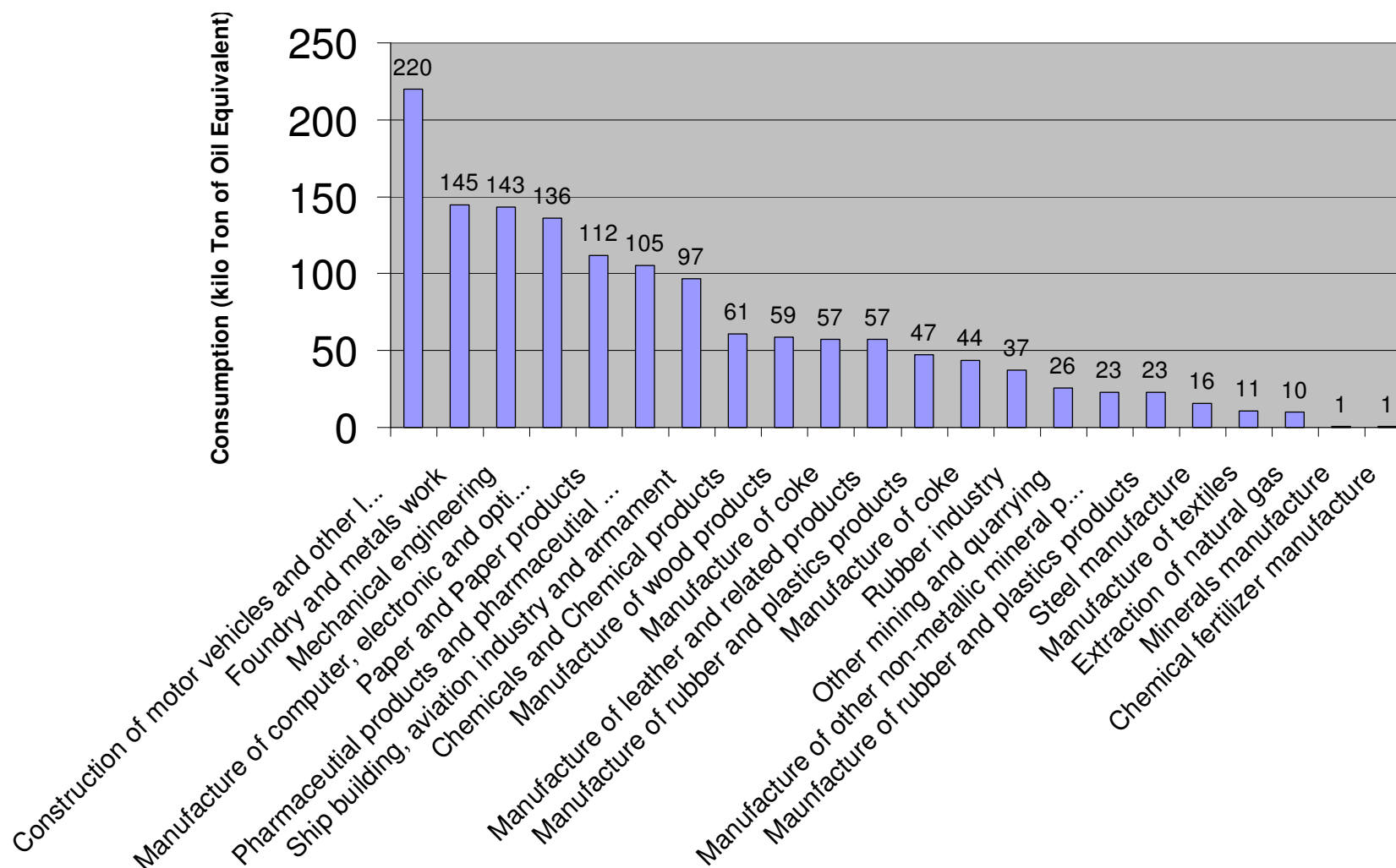

Industry Energy Consumption for process (2004)

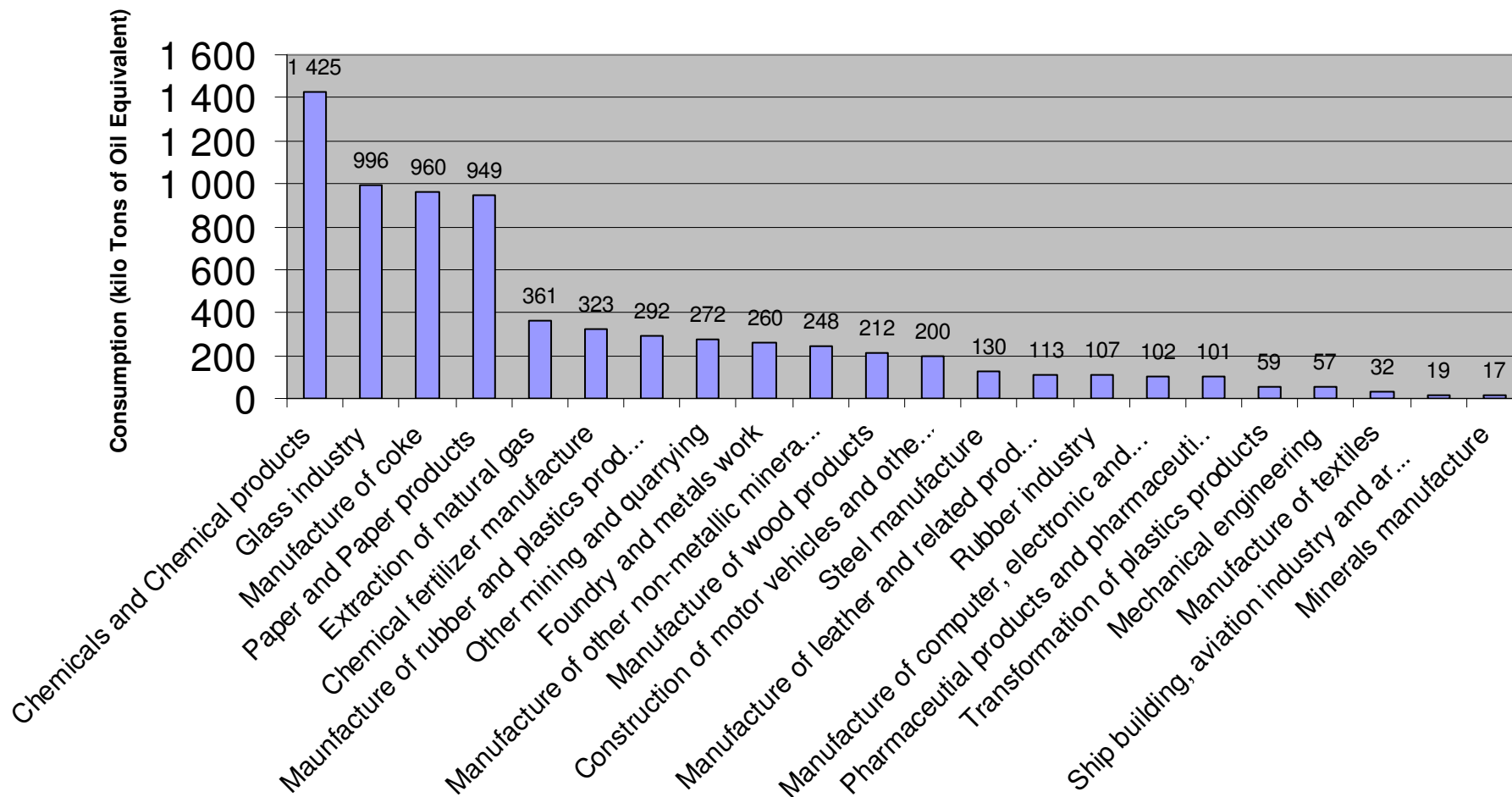

Sectors selection – Best present examples

Agriculture

Tropical plants production, Lamazère (Aquatania Basin), since 1992

Greenhouse size: 3,6 hectares

Water depth: 1 830m

Water temperature: 74 °C

Saving: 4 000 TOE/year

Fish farming

Caviar farming, Mios-le-Teich (Aquatania Basin)

Water depth: 1 830m

Water temperature: 74 °C

Saving: 4 000 TOE/year



District heating / cooling

29 plants still working in the Parisian Basin

Averaged water depth: 1800 m

Averaged water temperature: 70 °C



Industrial sectors selection

Main uses of geothermal applications contingent on temperatures

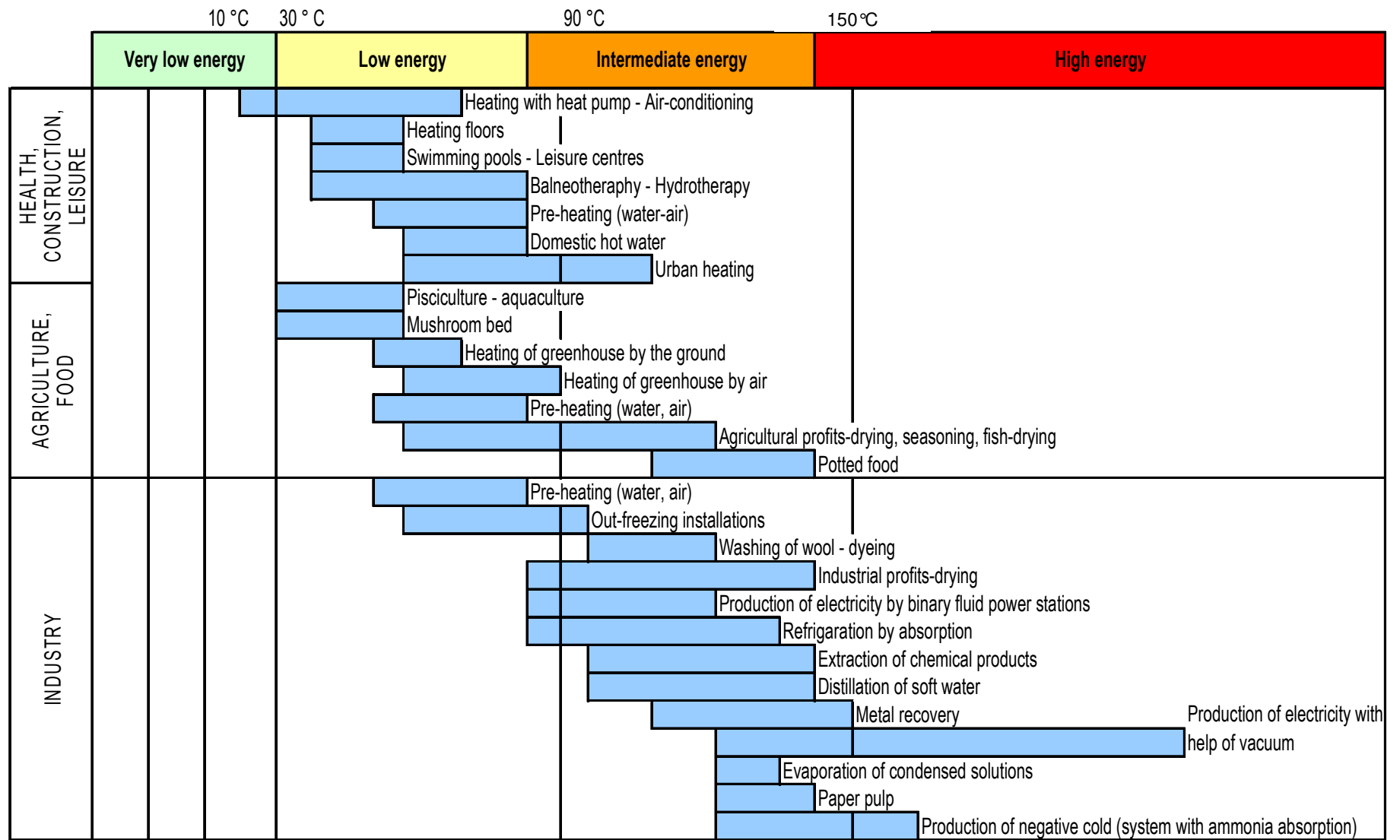

2 distinct applications:

- Heating/cooling of industrial buildings
- Industrial processes

Successive criteria

1. Matching of temperature levels
2. Matching of geothermal resource and needs
3. Market size

Phase II : Feasibility study

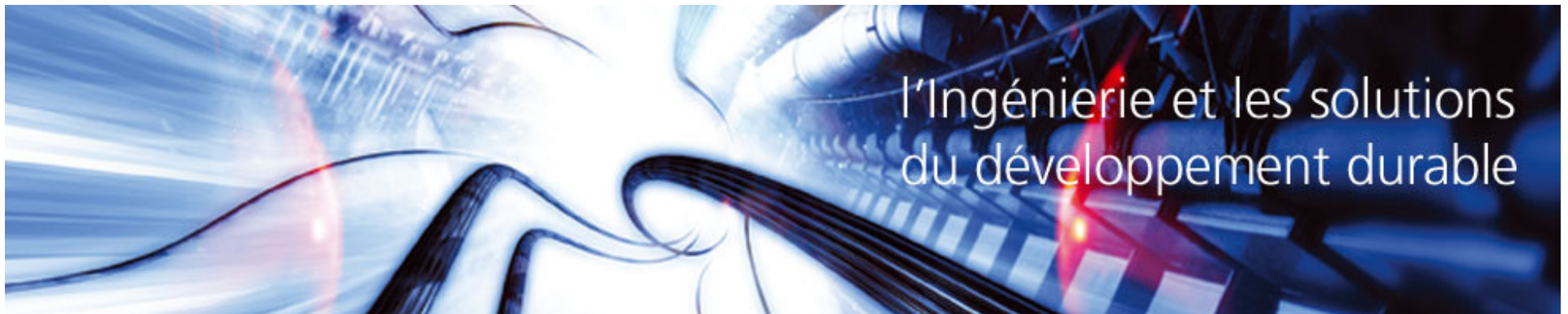

June 2008

- Commercial center
- 25 000 m²
- Perpignan (Mediterranean climate)

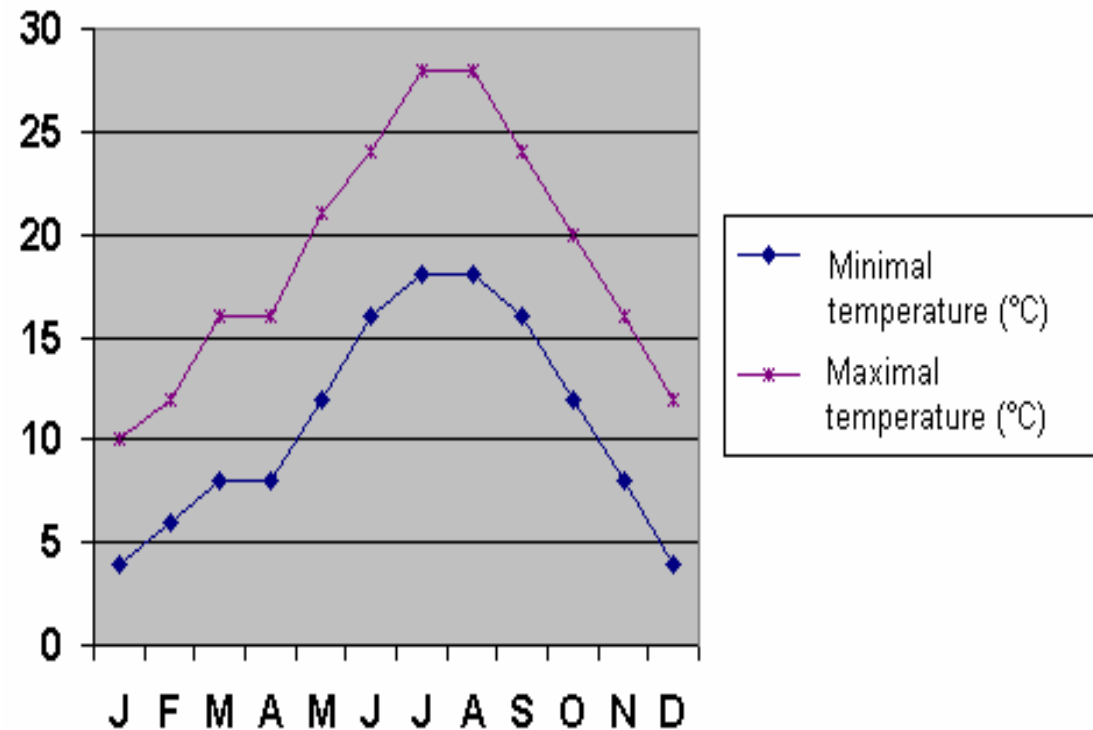

Load duration curve - Power demands

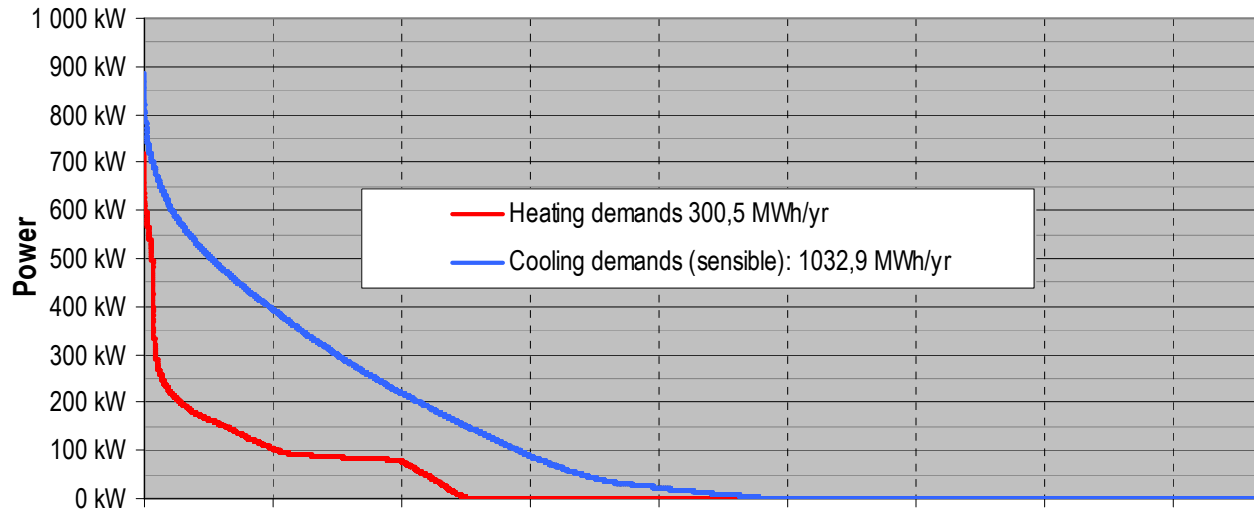

Energy demands

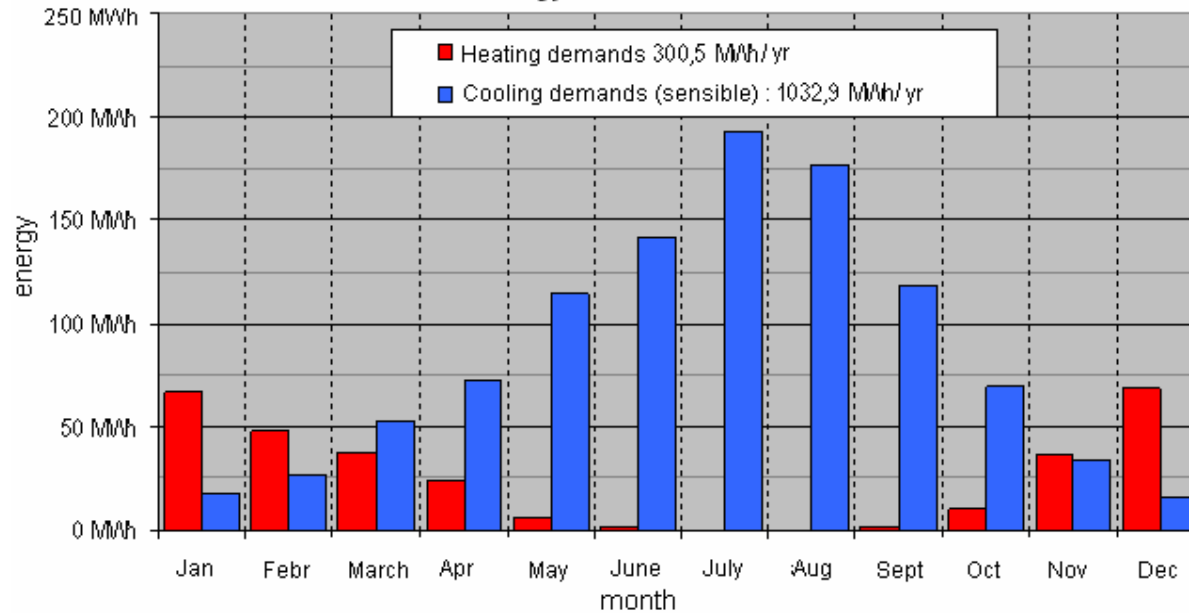

Hydrogeological conditions

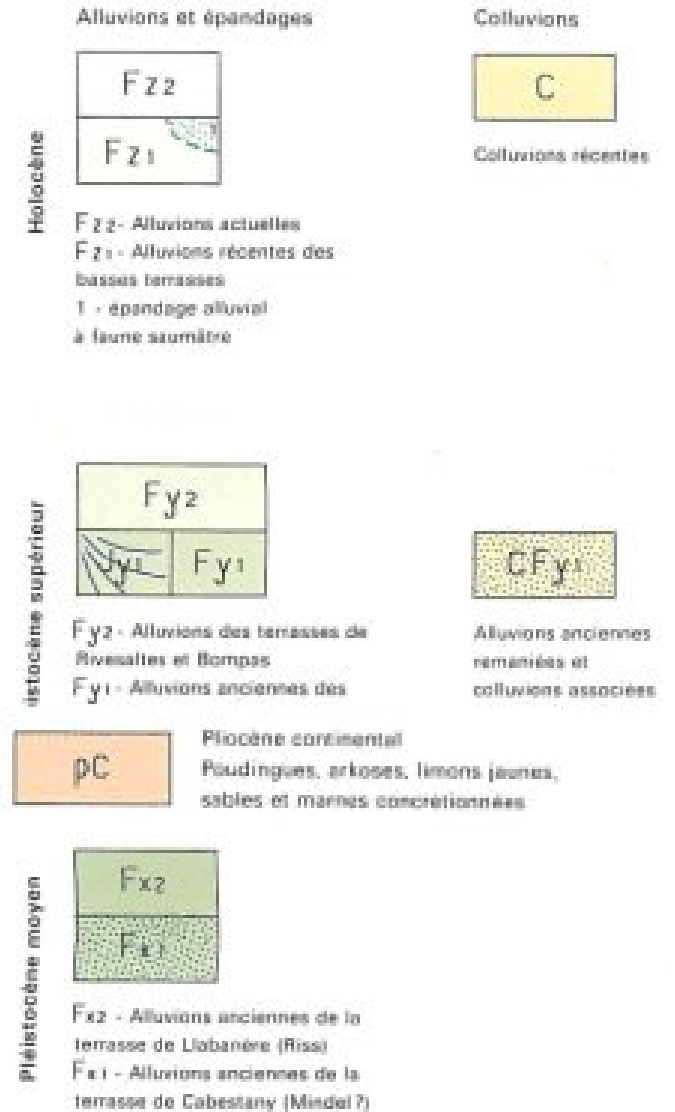
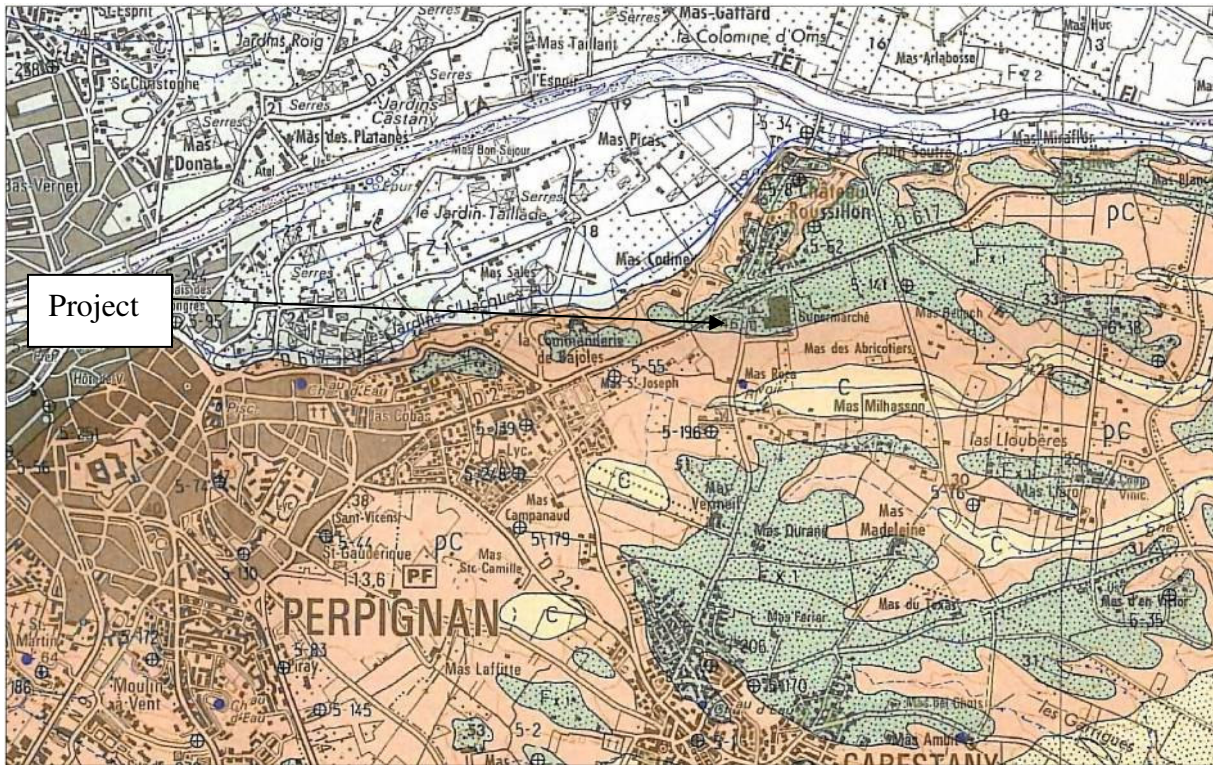

- Alternance of shale and sandy layers (Pliocene)
- Average water temperature : 20 °C
- Productivity : 100 m³/h
- Well depth : 200 m

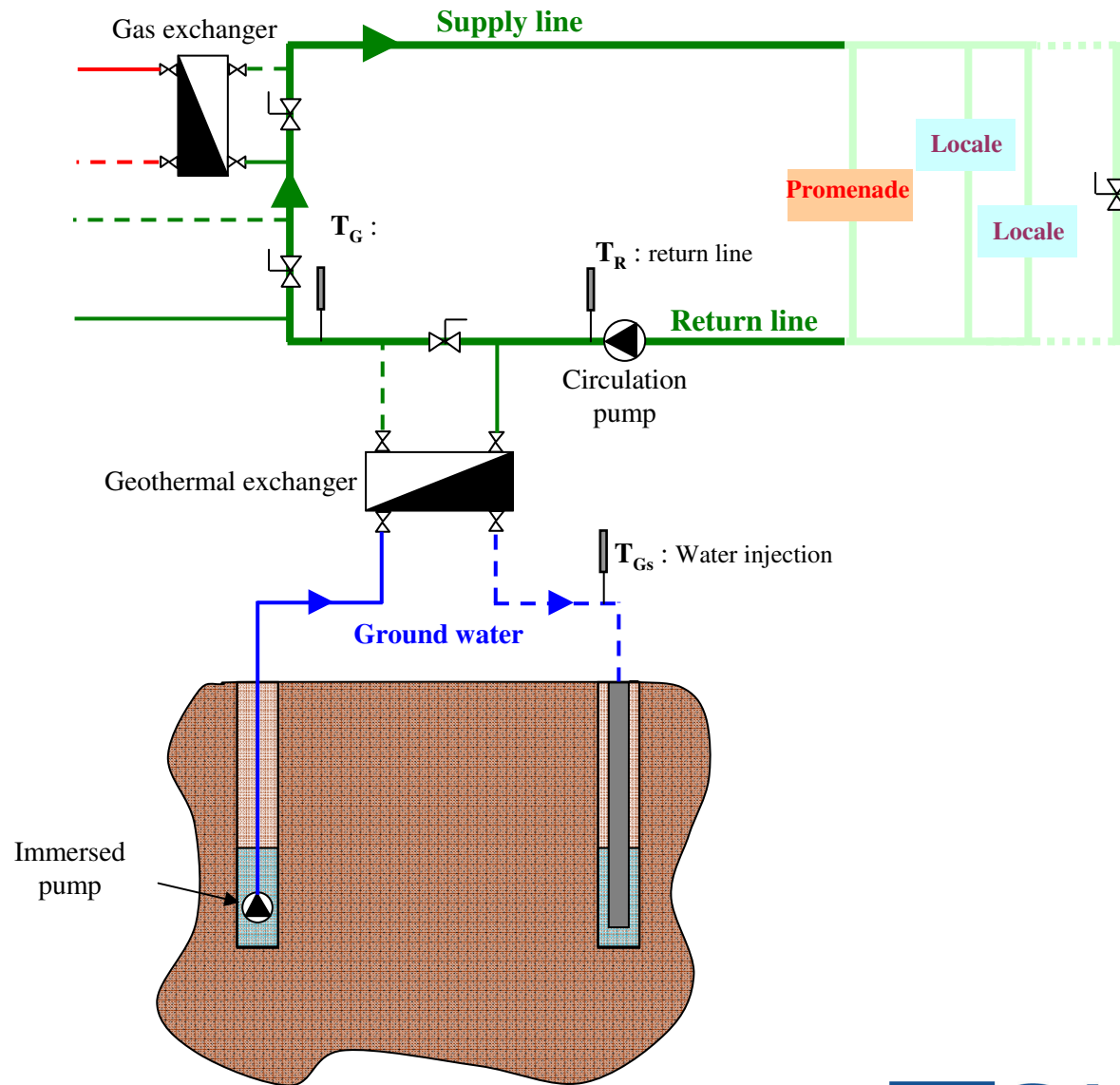

Drilling + junctions	
Site preparation	2 360 € exclusive VAT
Production well	126 750 € exclusive VAT
injection well	126 750 € exclusive VAT
Drill head premises	15 750 € exclusive VAT
Drill head	10 610 € exclusive VAT
immersed pump, pumping equipments	24 620 € exclusive VAT
Circuit box, casing, flow meter and sensor,	8 930 € exclusive VAT
Pipeline and surface cables	33 500 € exclusive VAT
TOTAL drillings + junctions	349 270 € exclusive VAT

Boiler room	
Geothermal heat exchanger (1+1 emergency)	21 000 € exclusive VAT
Surplus - Promenade emitters + loop pump	28 622 € exclusive VAT
Depreciation gas boilers (-1)	-20 000 € exclusive VAT
Depreciation air coolers (-1)	-36 000 € exclusive VAT
Régulation / Others	10 000 € exclusive VAT
TOTAL Boiler room	3 622 € exclusive VAT

TOTAL Overinvestment	352 892 € exclusive VAT
-----------------------------	--------------------------------

Decrease of the energetic expenditure of **6 868 € exclusive VAT/yr (14%)**.